

SERVICE INSTRUCTIONS

www.keatingofchicago.com

KEATING
OF CHICAGO, INC.®

1-800-KEATING

DELAYED IGNITION OR FAILED RECTIFICATION INCREDIBLE FRYING MACHINE

All installation and service on Keating equipment must be performed by qualified, certified, licensed and/or authorized installation or service personnel.

- Check gas pressure at the manifold with the fryer operating and all gas equipment in the kitchen turned on and operating.

Natural gas – 7" (line), 3" water column at the manifold

LP gas – 11" (line), 10" water column at the manifold

- Check both gaps on spark electrode by removing the burner.

Pilot tube and electrode 0.125 (1/8")

Pilot tube and burner 0.125 (1/8")

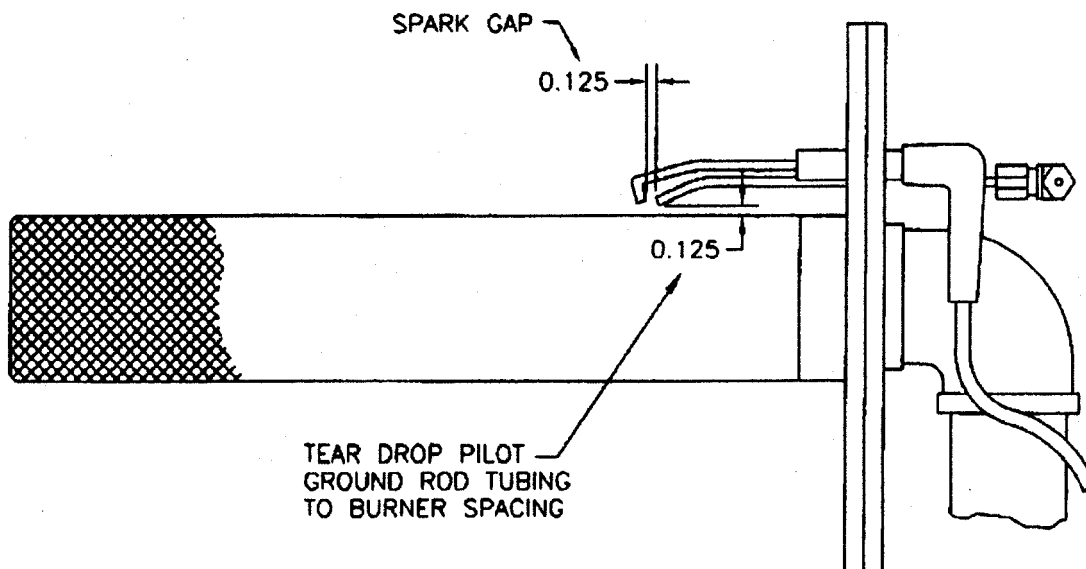

PROCEDURE

1. Remove the entire burner assembly. Only disconnect the spark leads from the spark module. Leave the other end connected to the spark electrode.
2. Adjust the gap between the electrode and burner (0.125).
3. Adjust the spark between the pilot tube and electrode (0.125).
4. Remount the burner assembly.
5. Reconnect the high voltage lead to the spark module.